

These slides are for use with

Database Systems

Concepts, Languages and Architectures

Paolo Atzeni • Stefano Ceri • Stefano Paraboschi • Riccardo Torlone
© McGraw-Hill 1999

Concepts,
Languages
and
Architectures

Paolo Atzeni,
Stefano Ceri,
Stefano Paraboschi
and Riccardo Torlone

Mc
Graw
Hill

To view these slides on-screen or with a projector use the arrow keys to move to the next or previous slide. The return or enter key will also take you to the next slide. Note you can press the 'escape' key to reveal the menu bar and then use the standard Acrobat controls — including the magnifying glass to zoom in on details.

To print these slides on acetates for projection use the escape key to reveal the menu and choose 'print' from the 'file' menu. If the slides are too large for your printer then select 'shrink to fit' in the print dialogue box.

Press the 'return' or 'enter' key to continue . . .

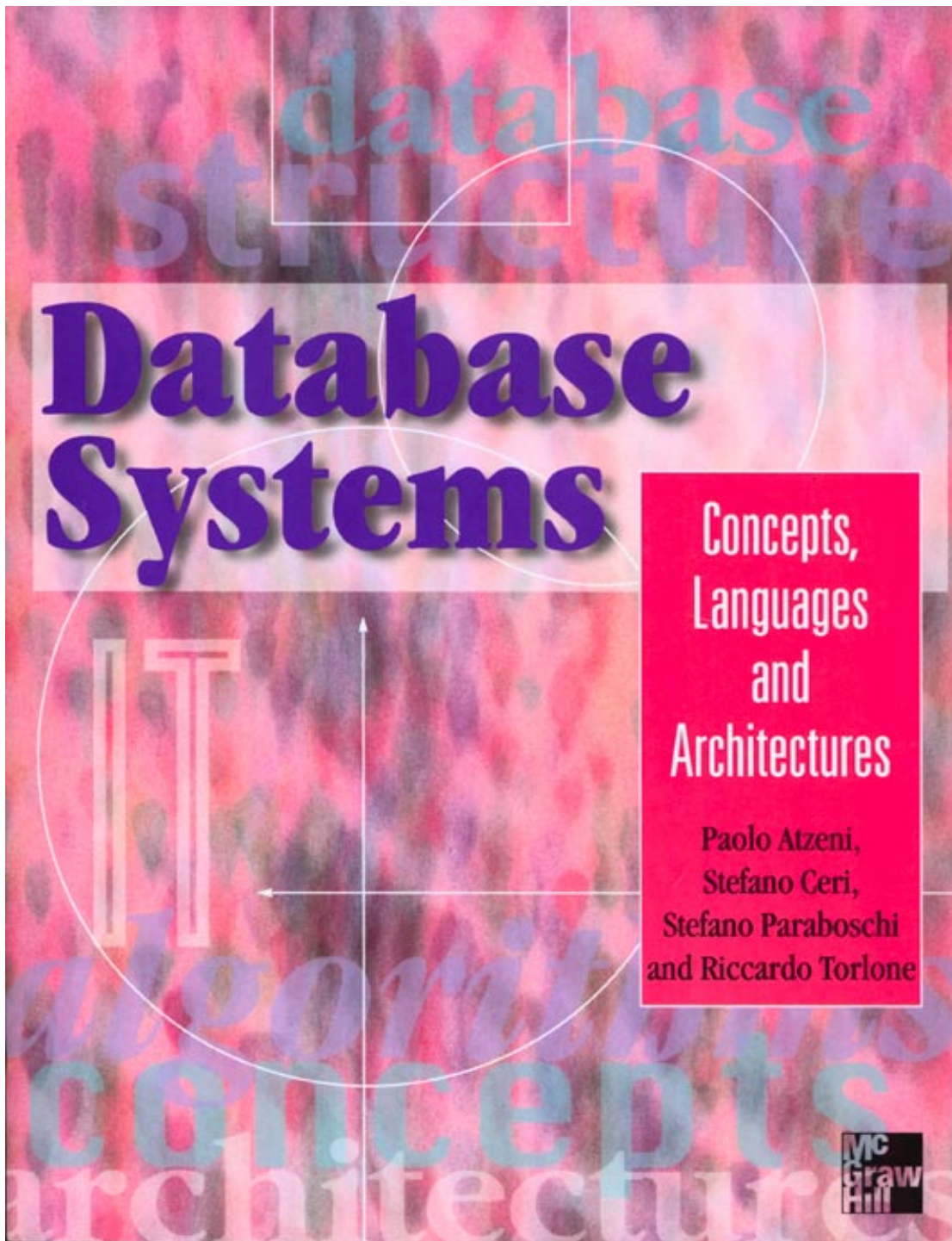

Chapter 5

Design
techniques
and models

Database design

- Database design is just one of the many activities in the development of an information system within an organization;
- it should therefore be presented within the wider context of the information system life cycle.

Life cycle of an information system

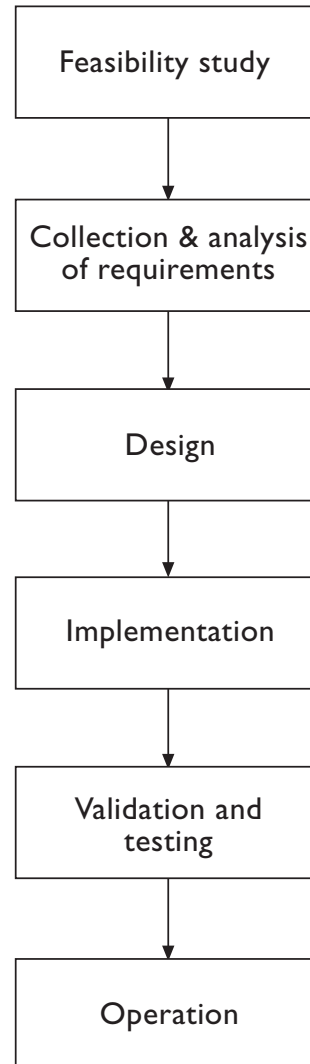

Phases of information system life cycle

- **Feasibility study.** It serves to define the costs of the various possible solutions and to establish the priorities for the creation of the various components of the system.
- **Collection and analysis of requirements.** It consists of the definition and study of the properties and functionality of the information system.
- **Design.** It is generally divided into two tasks: *database design* and *operational design*.
- **Implementation.** It consists of the creation of the information system according to the characteristics defined in the design.
- **Validation and testing.** This is to check the correct functioning and quality of the information system.
- **Operation.** The information system becomes live and performs the tasks for which it was originally designed.

Information systems and databases

- The database constitutes only one of the components of an information system, which also includes application programs, user interfaces and other service programs.
- However, the central role that the data itself plays in an information system more than justifies an independent study of database design.
- For this reason, we deal with only those aspects of information system development that are closely of databases, focusing on data design and on the related activities of collection and analysis of the requirements.

Methodologies for database design

- We follow a structured approach to database design that can be regarded as a 'design methodology'.
- As such, it is presented by means of:
 - a *decomposition* of the entire design activity in successive steps, independent one from the other;
 - a series of *strategies* to be followed in the various steps and some *criteria* from which to choose in the case of there being options;
 - some *reference models* to describe the inputs and outputs of the various phases.

A database design methodology

- Within the field of databases, a design methodology has been consolidated over the years.
- It is based on a simple but highly efficient engineering principle: separate the decisions relating to 'what' to represent in the database, from those relating to 'how' to do it.
- This methodology is divided into three phases to be followed consecutively.

The phases of database design

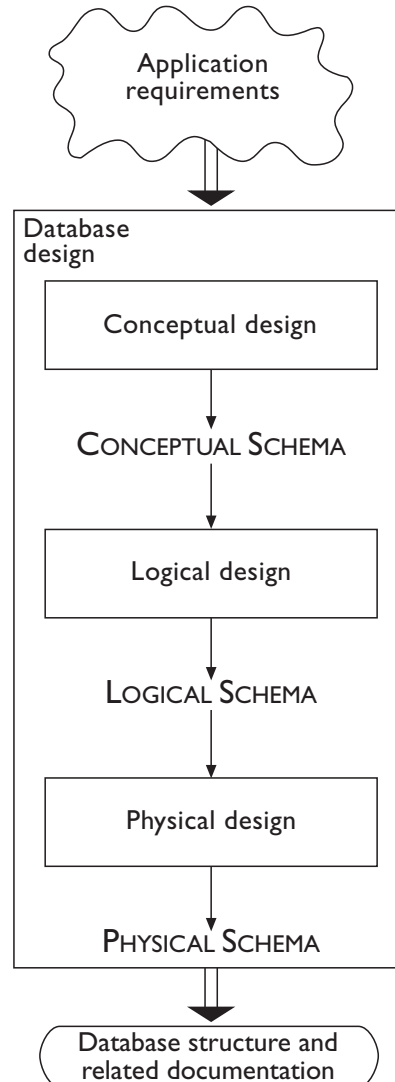

Phases of database design

- **Conceptual design.** The purpose of this is to represent the informal requirements of an application in terms of a *conceptual schema* that refers to a *conceptual data model*.
- **Logical design.** This consists of the translation of the conceptual schema defined in the preceding phase, into the *logical schema* of the database that refers to a *logical data model*.
- **Physical design.** In this phase, the logical schema is completed with the details of the physical implementation (file organization and indexes) on a given DBMS. The product is called the *physical schema* and refers to a *physical data model*.

The products of the various phases of a relational database with the E-R model

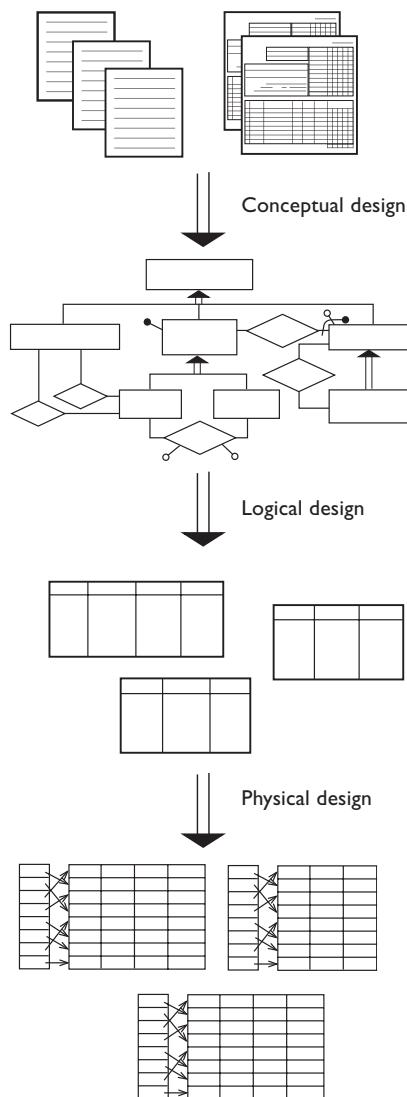

The Entity Relationship model

- The **Entity-Relationship** (E-R) model is a *conceptual* data model, and as such provides a series of *constructs* capable of describing the data requirements of an application in a way that is easy to understand and is independent of the criteria for the management and organization of data on a database system.
- For every construct, there is a corresponding graphical representation. This representation allows us to define an E-R schema diagrammatically.

The constructs of the E-R model and their graphical representation

Construct	Graphical representation
Entity	
Relationship	
Simple attribute	
Composite attribute	
Cardinality of a	
Cardinality of an attribute	
Internal identifier	
External identifier	
Generalization	
Subset	

Entities

- These represent classes of objects (facts, things, people, for example) that have properties in common and an autonomous existence.
- CITY, DEPARTMENT, EMPLOYEE, PURCHASE and SALE are examples of entities in an application for a commercial organization.
- An occurrence of an entity is an object of the class that the entity represents.

Examples of entity of the E-R model

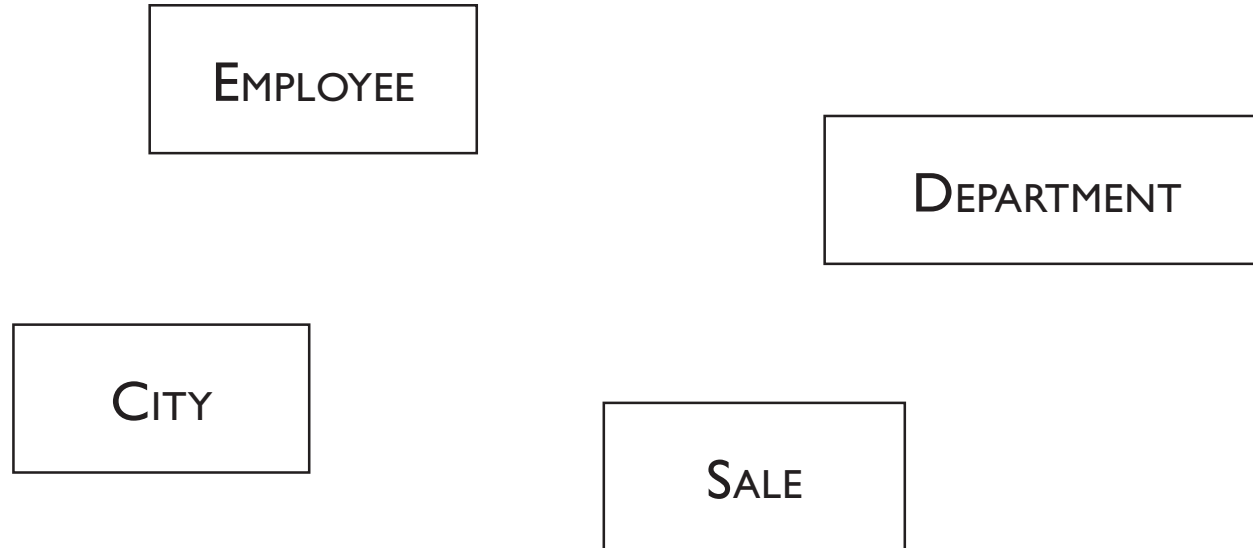

Relationships

- They represent logical links between two or more entities.
- RESIDENCE is an example of a relationship that can exist between the entities CITY and EMPLOYEE; EXAM is an example of a relationship that can exist between the entities STUDENT and COURSE.
- An occurrence of a relationship is an n-tuple made up of occurrences of entities, one for each of the entities involved.

Example of occurrences of the EXAM relationship

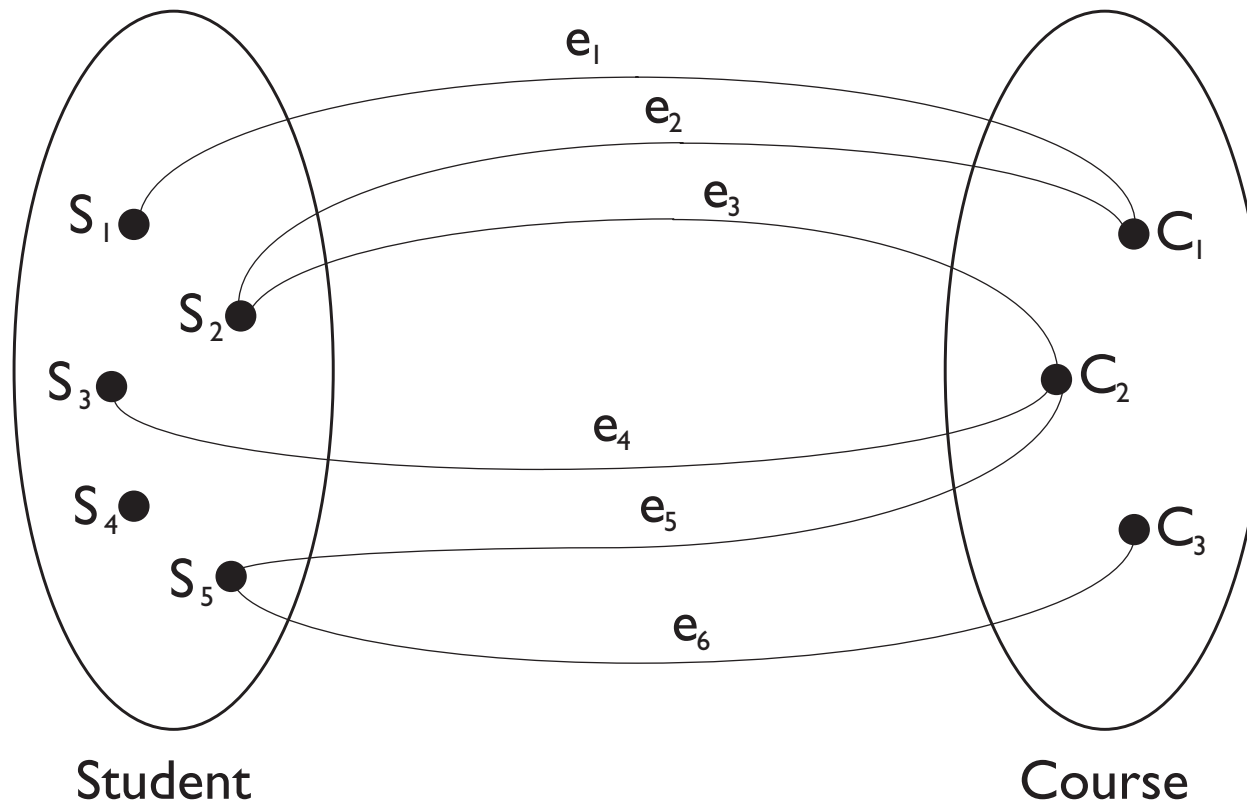

Examples of relationships in the E-R model

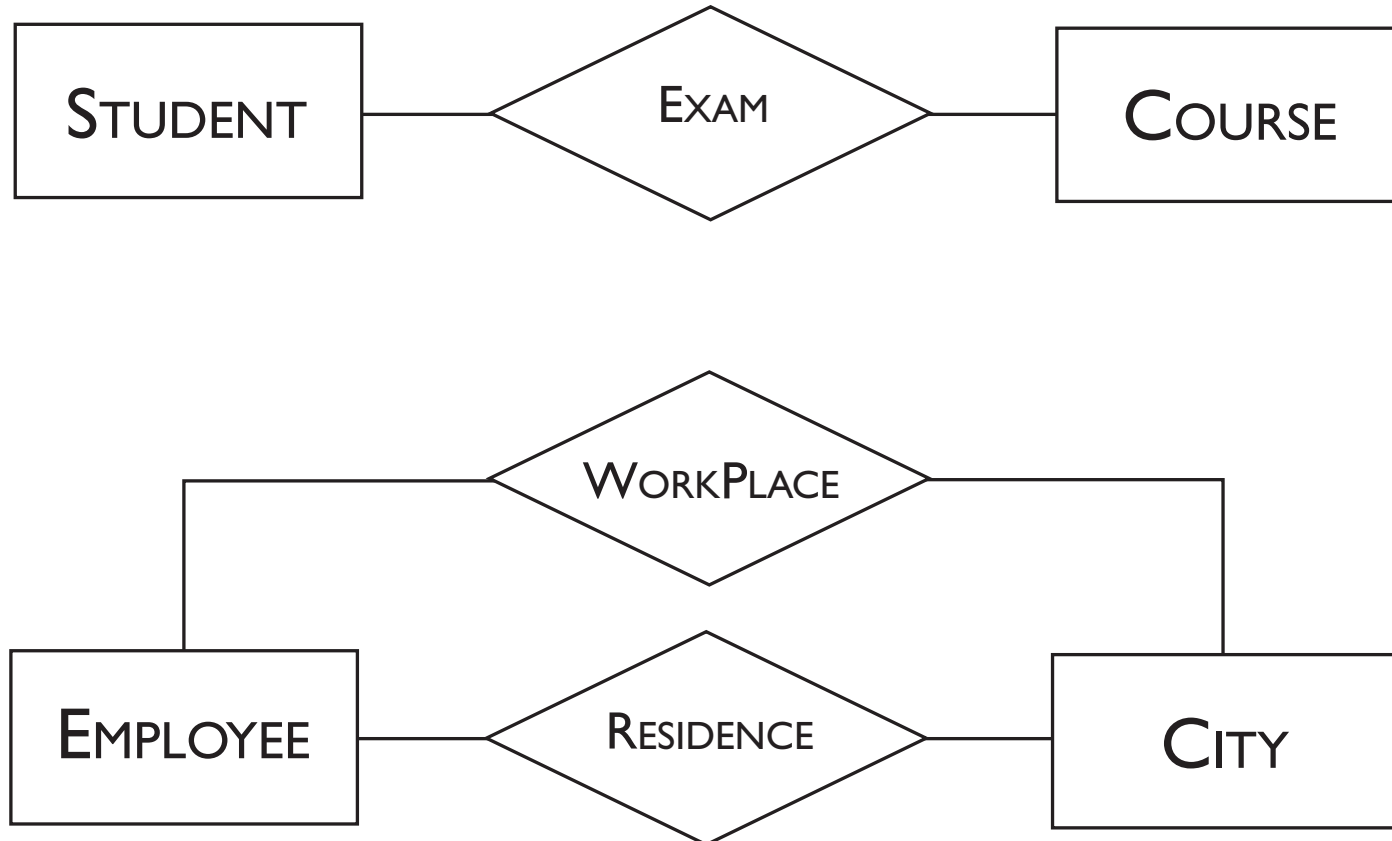

Examples of recursive relationships in the E-R model

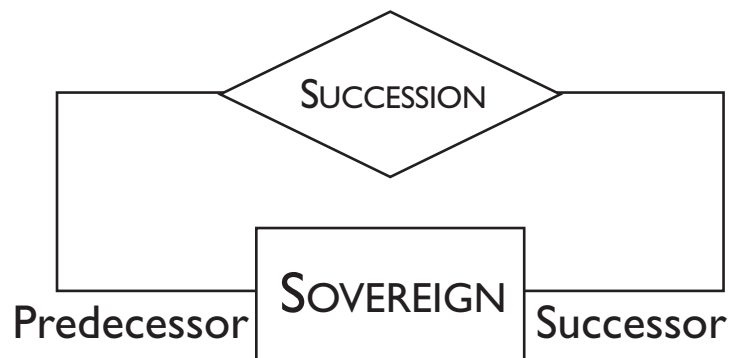
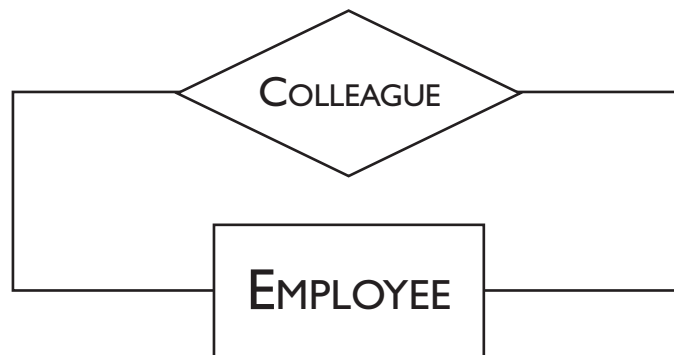

Example of a ternary relationship in the E-R model

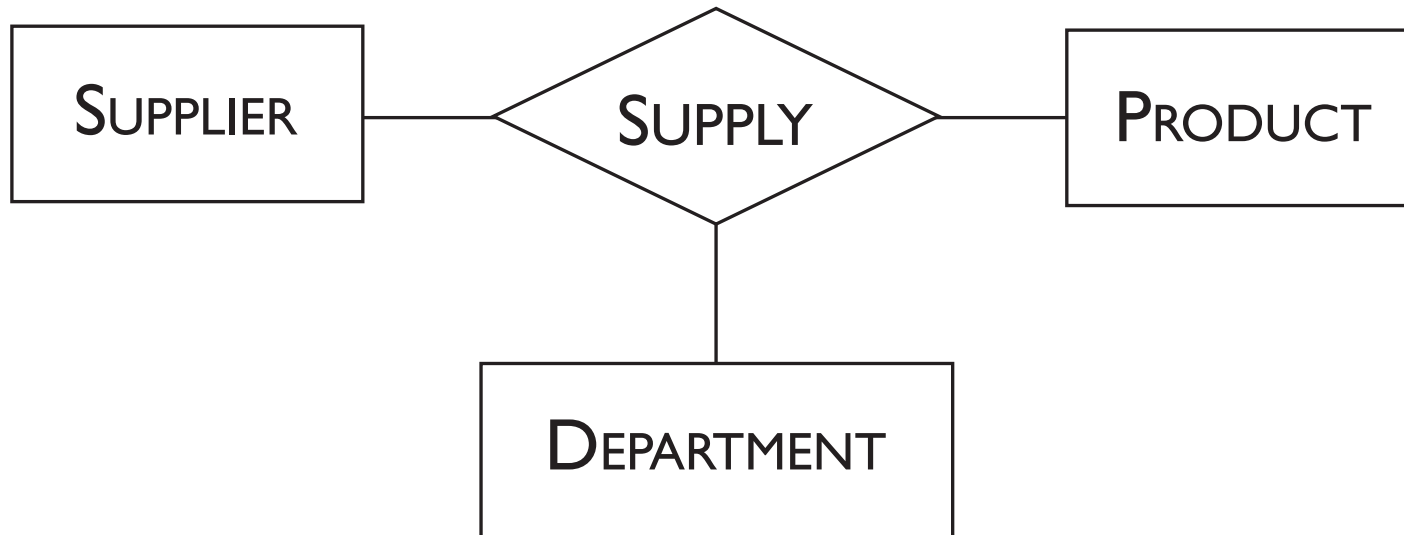

Example of occurrences of the SUPPLY relationship

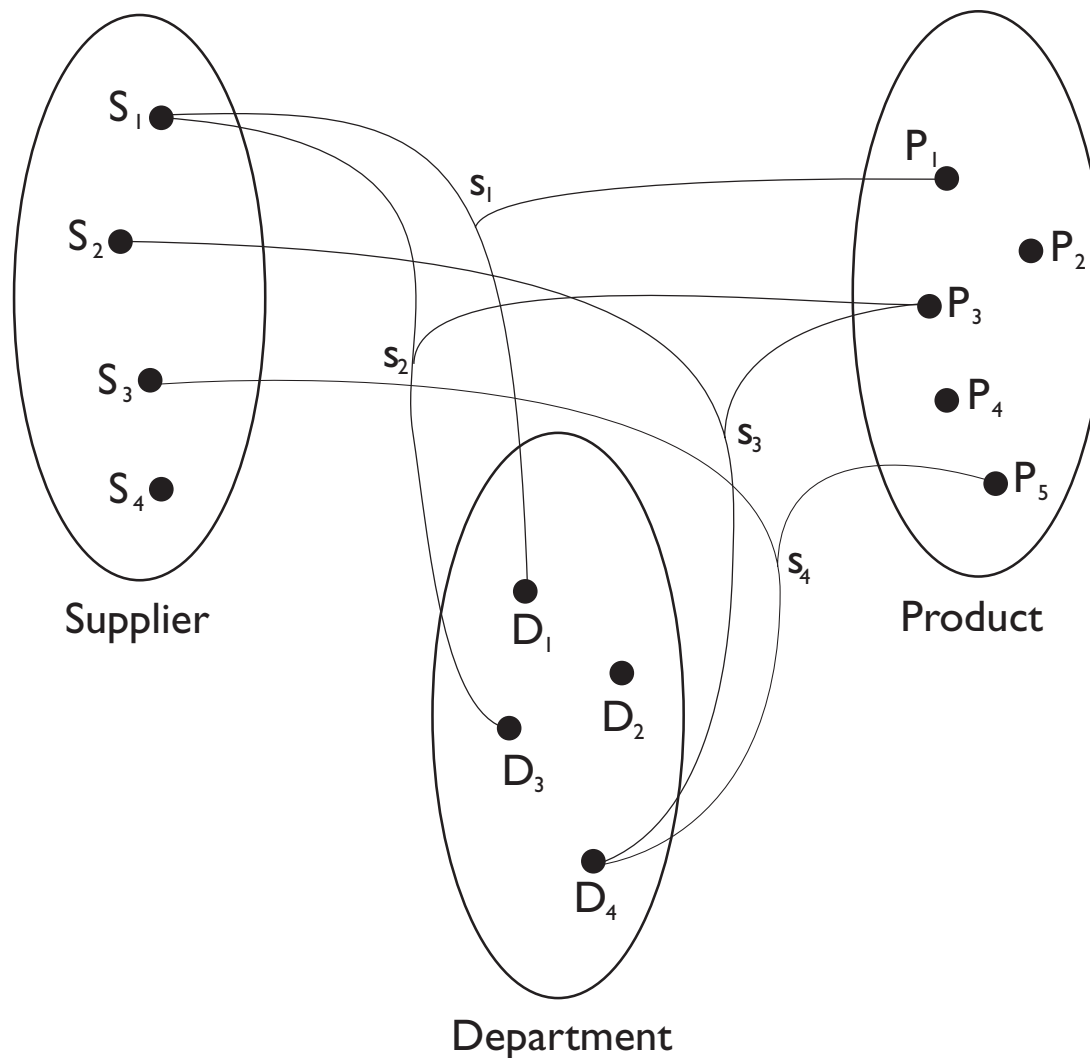

Attributes

- These describe the elementary properties of entities or relationships.
- Surname, Salary and Age are possible attributes of the EMPLOYEE entity, while Date and Mark are possible attributes for the relationship EXAM between STUDENT and COURSE.
- An attribute associates with each occurrence of an entity (or relationship) a value belonging to a set known as the domain of the attribute.
- The domain contains the admissible values for the attribute.

E-R schemas with relationships, entities and attributes

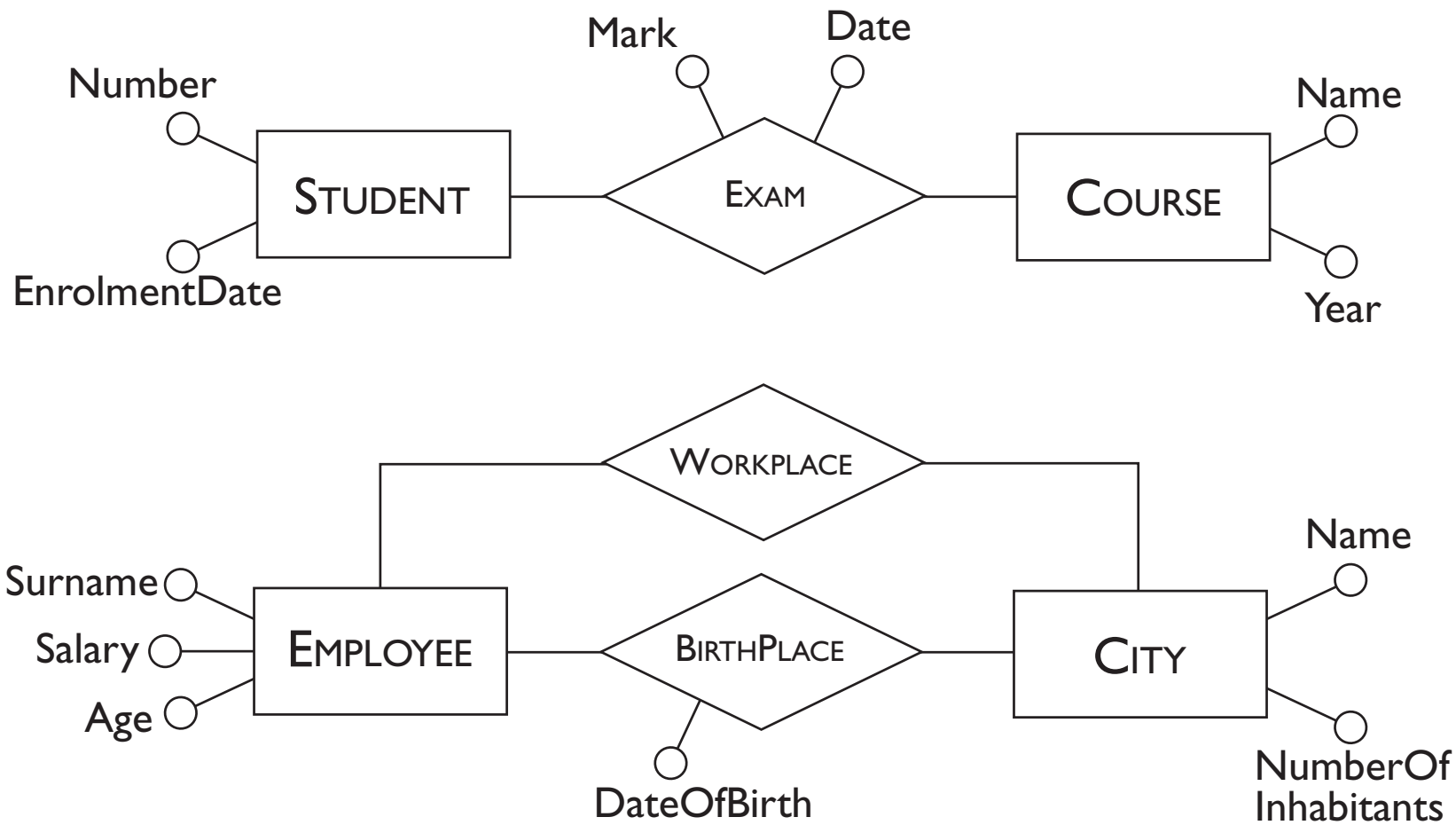

An example of an entity with a composite attribute

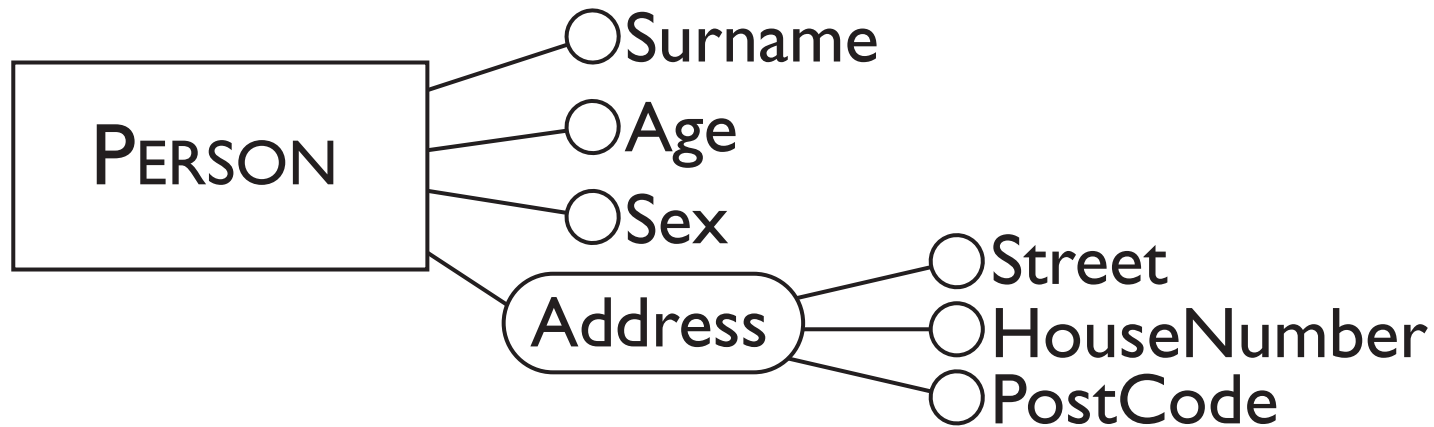

An Entity-Relationship schema

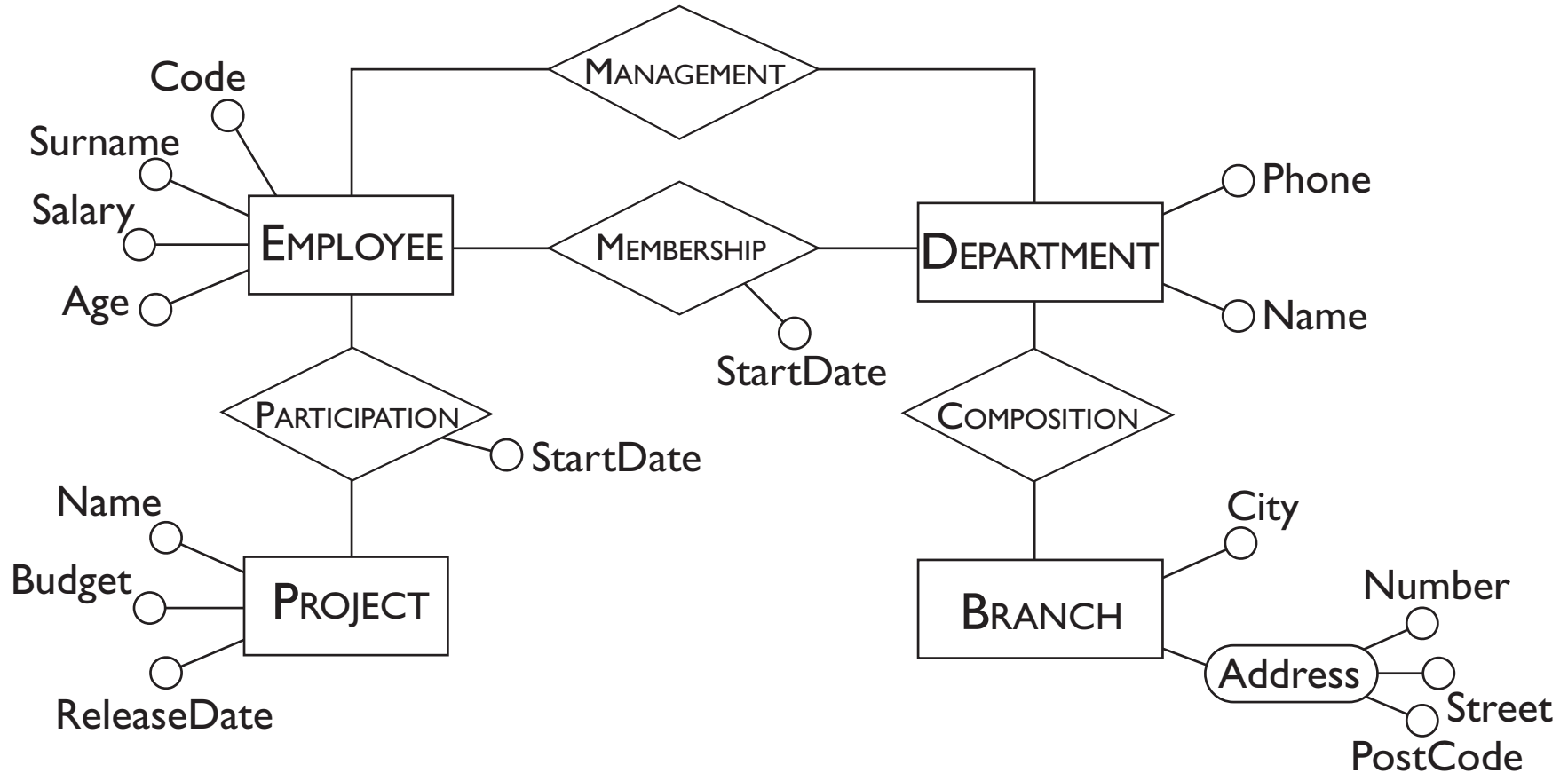

Cardinalities

- They are specified for each entity participating in a relationship and describe the maximum and minimum number of relationship occurrences in which an entity occurrence can participate.
- They state therefore how many times in a relationship between entities an occurrence of one of these entities can be linked to occurrences of the other entities involved.

Cardinality of a relationship in the E-R model



Values for cardinalities

- In most cases, it is sufficient to use only three values for cardinalities: zero, one and the symbol N:
 - for the minimum cardinality, zero or one; in the first case we say that the participation in the relationship is *optional*, in the second we say that the participation is *mandatory*;
 - for the maximum cardinality, one or many (N); in the first case each occurrence of the entity is associated at most with a single occurrence of the relationship, while in the second case each occurrence of the entity is associated with an arbitrary number of occurrences of the relationship.

Examples of cardinality of relationships

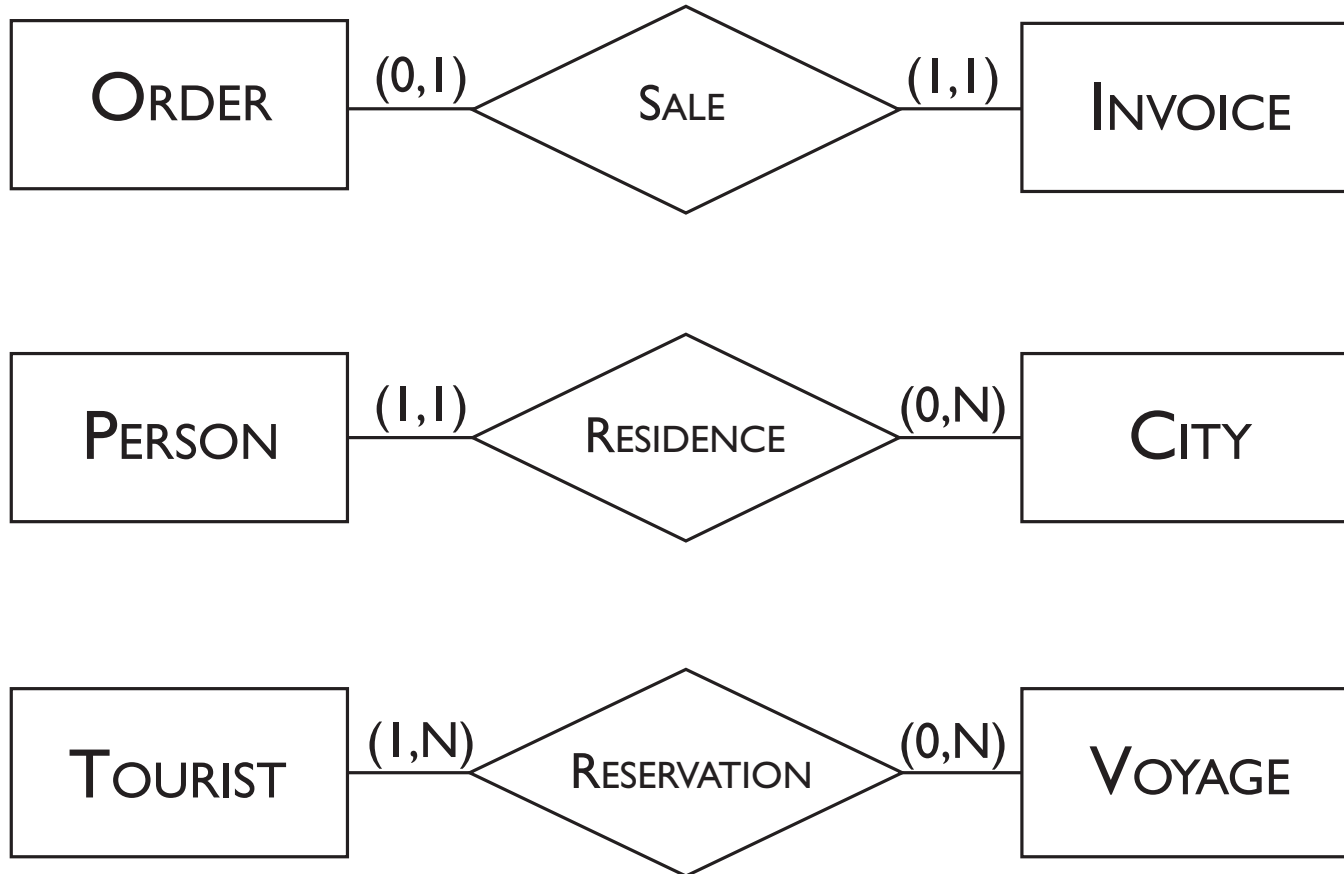

Cardinalities of attributes

- They can be specified for the attributes of entities (or relationships) and describe the minimum and maximum number of values of the attribute associated with each occurrence of an entity or a relationship.
- In most cases, the cardinality of an attribute is equal to (1,1) and is omitted.
- The value of a certain attribute can be null or there can exist various values of a certain attribute associated with an entity occurrence.

Example of entity attributes with cardinality

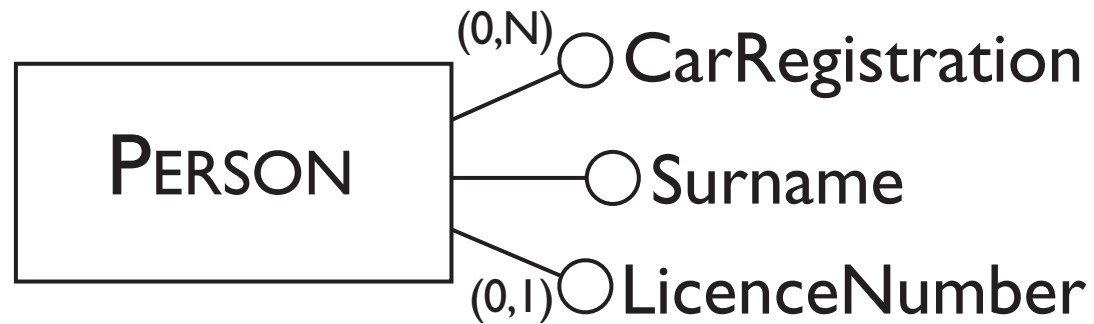

Identifiers

- They are specified for each entity of a schema and describe the concepts (attributes and/or entities) of the schema that allow the unambiguous identification of the entity occurrences.
- In many cases, an identifier is formed by one or more attributes of the entity itself: in this case we talk about an *internal* identifier (also known as a *key*).
- Sometimes, however, the attributes of an entity are not sufficient to identify its occurrences unambiguously and other entities need to be involved in the identification. This is called an *external* identifier.

Examples of internal and external identifiers

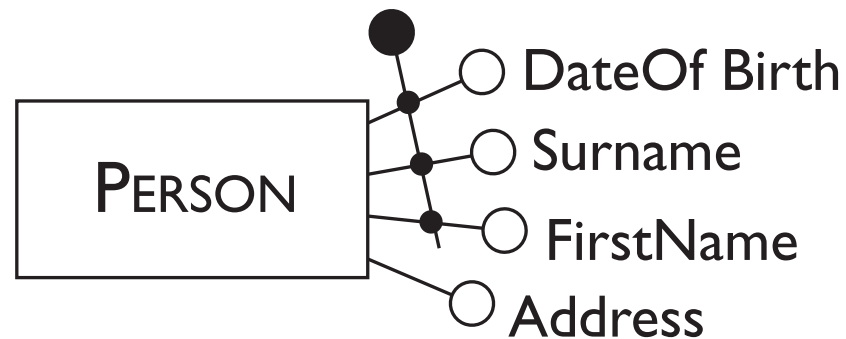
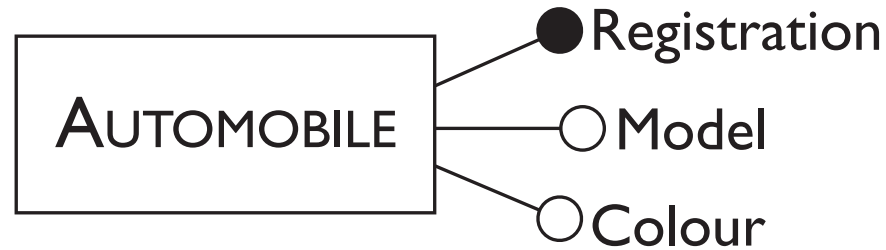

Example of an external entity identifier

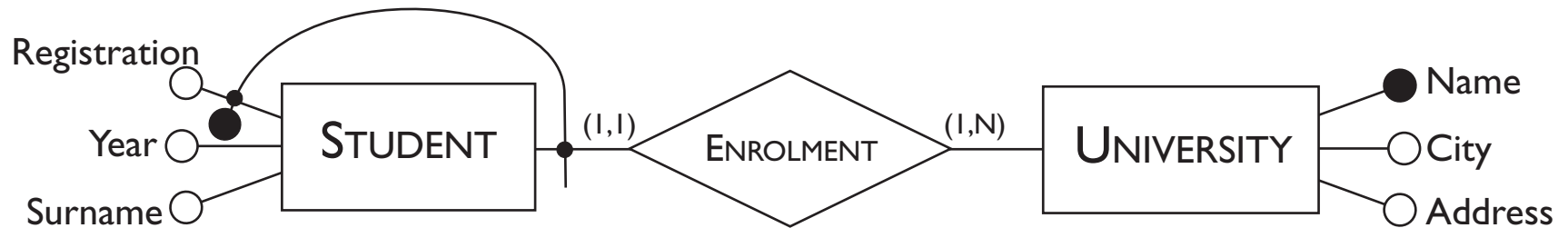

General observations on identifiers

- An identifier can involve one or more attributes, provided that each of them has (1,1) cardinality;
- an external identifier can involve one or more entities, provided that each of them is member of a relationship to which the entity to identify participates with cardinality equal to (1,1);
- an external identifier can involve an entity that is in its turn identified externally, as long as cycles are not generated;
- each entity must have one (internal or external) identifier, but can have more than one. Actually, if there is more than one identifier, then the attributes and entities involved in an identification can be optional (minimum cardinality equal to 0).

A schema completed by identifiers and cardinality

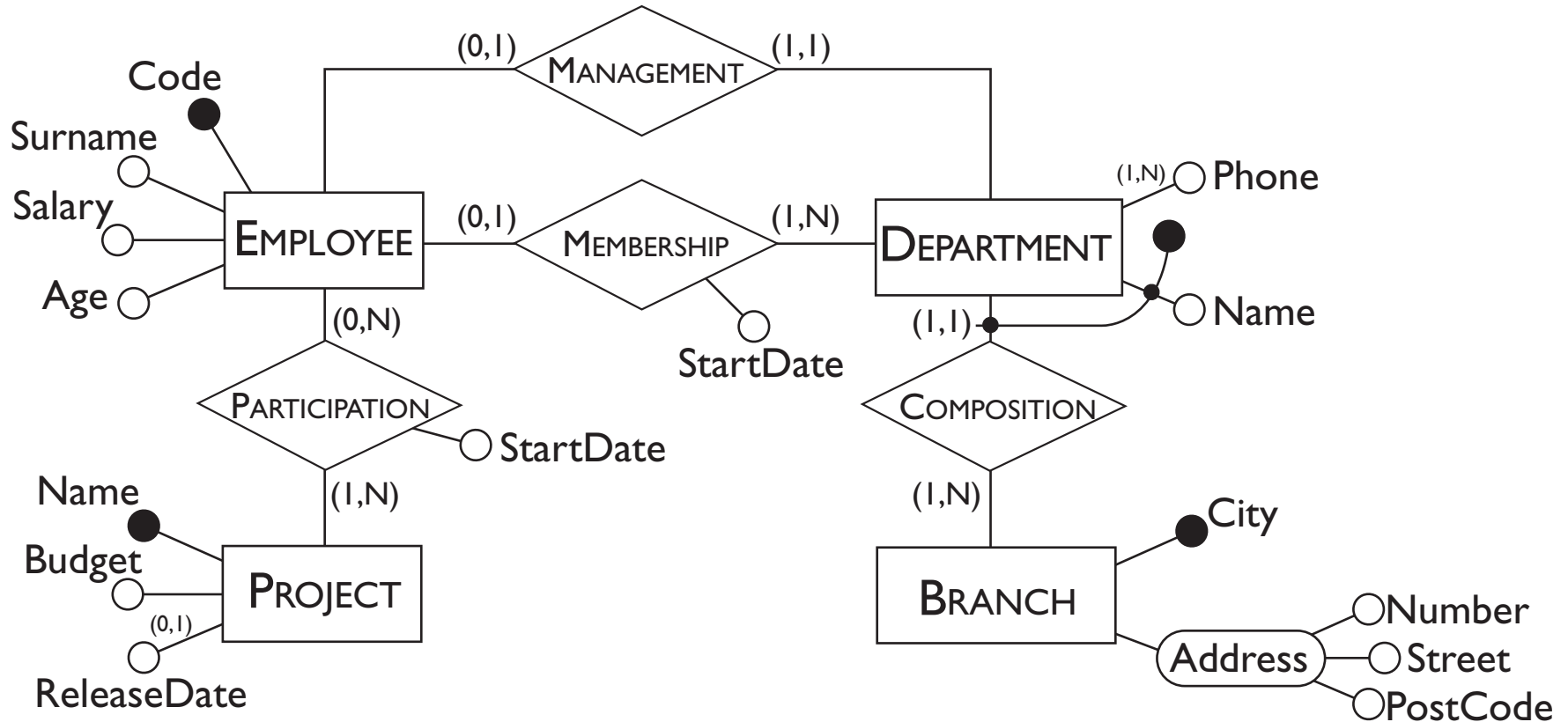

Generalizations

- These represent logical links between an entity E , known as *parent* entity, and one or more entities E_1, \dots, E_n called *child* entities, of which E is more general, in the sense that it comprises them as a particular case.
- In this situation we say that E is a *generalization* of E_1, \dots, E_n and that the entities E_1, \dots, E_n are *specializations* of the E entity.

Examples of generalizations among entities

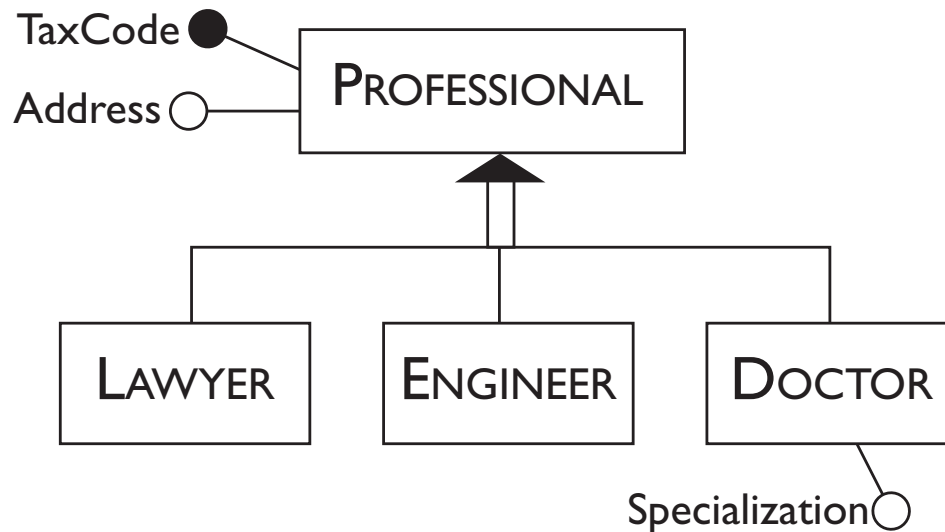
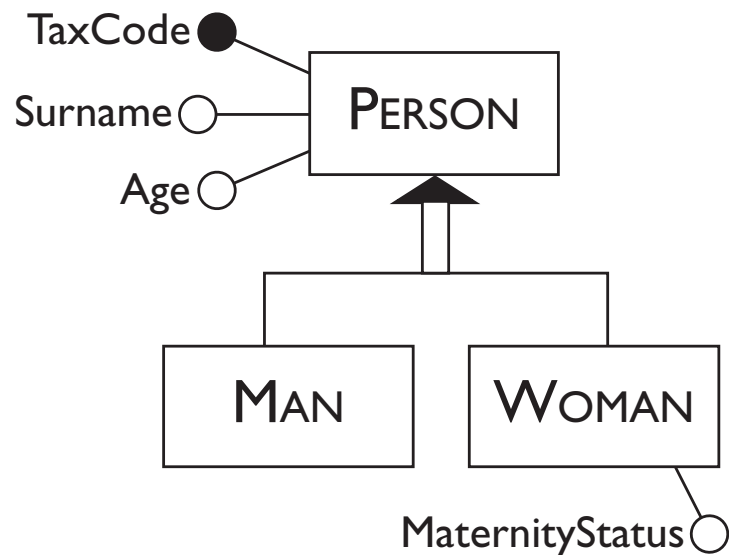

Properties of generalizations

- Every occurrence of a child entity is also an occurrence of the parent entity.
- Every property of the parent entity (attributes, identifiers, relationships and other generalizations) is also a property of a child entity. This property of generalizations is known as *inheritance*.

Classification of generalizations

- A generalization is *total* if every occurrence of the parent entity is also an occurrence of one of the child entities, otherwise it is *partial*;
- A generalization is *exclusive* if every occurrence of the parent entity is at most an occurrence of one of the child entities, otherwise it is *overlapping*.

Hierarchy of generalizations between entities

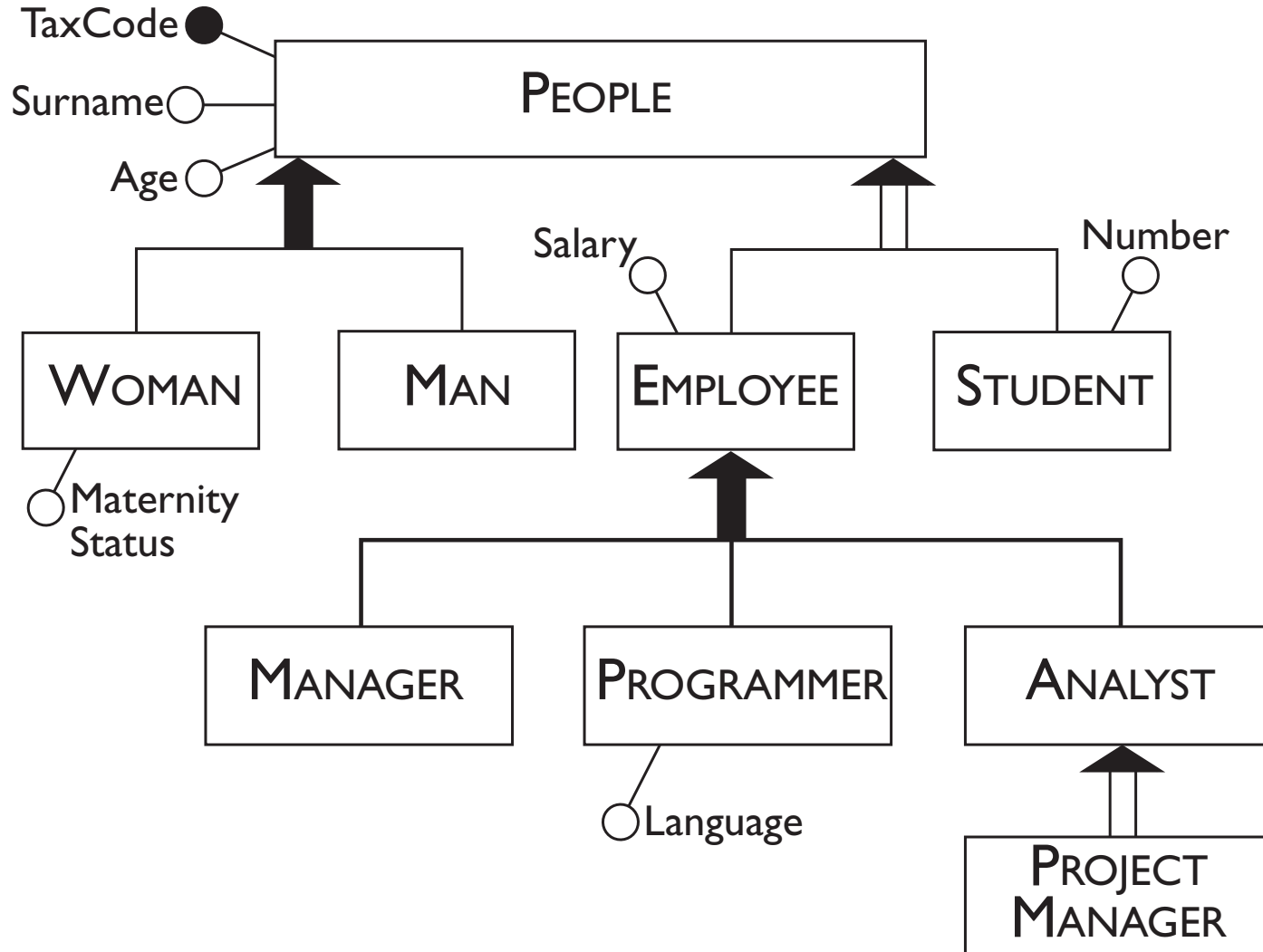

Description of the E-R model using the E-R model

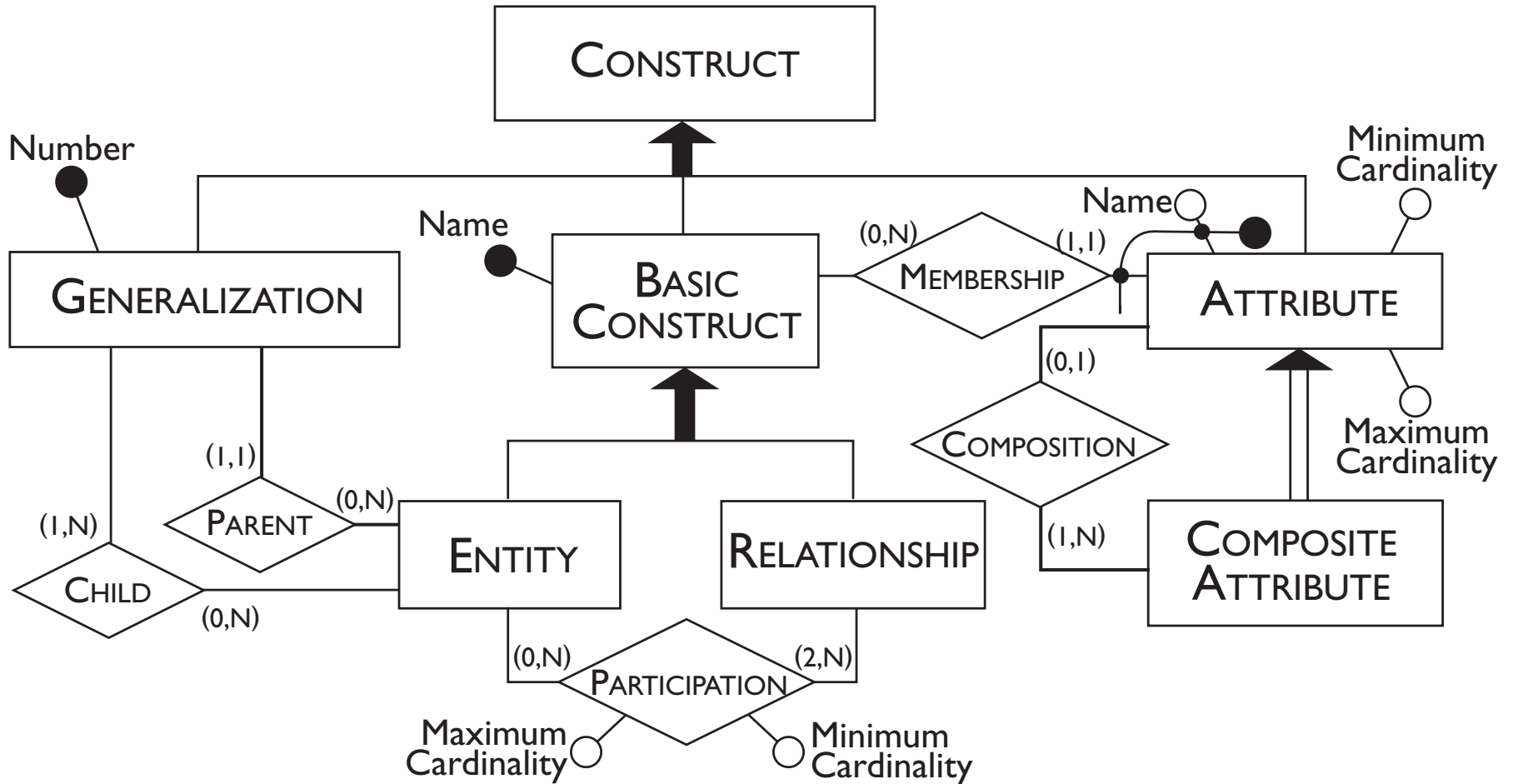

Documentation of E-R schemas

- An Entity-Relationship schema is rarely sufficient by itself to represent all the aspects of an application in detail;
- it is therefore indispensable to provide every E-R schema with support documentation, which can facilitate the interpretation of the schema itself and describe properties of the data that cannot be expressed directly by the constructs of the model;
- a widespread documentation tool for conceptual schemas is the *business rule*.

Business rules

- Business rules are one of the tools used by information systems analysts to describe the properties of an application.
- According to a widespread classification a business rule can be:
 - the description of a concept relevant to the application,
 - an integrity constraint on the data of the application,
 - a derivation, or rather a concept that can be obtained, by means of an inference or an arithmetical calculation, by other concepts of the schema.

Documentation techniques

- Descriptive business rules can be organized as a *data dictionary*. This is made up of two tables: the first describes the entities of the schema, the others describes the relationships.
- Business rules that describe constraints can be expressed in the following form:

<concept> must/must not <expression on concepts>
- Business rules that describe derivations can be expressed in the following form:

<concept> is obtained by <operations on concepts>

Example of a data dictionary

Entity	Description	Attributes	Identifier
EMPLOYEE	Employee working in the company.	Code, Surname, Salary, Age	Code
PROJECT	Company project on which employees are working.	Name, Budget, ReleaseDate	Name
....

Relationship	Description	Entities involved	Attributes
MANAGEMENT	Associate a manager with a department.	Employee (0,1), Department (1,1)	
MEMBERSHIP	Associate an employee with a department.	Employee (0,1) Department (1,N)	StartDate
....

Example of business rules

Constraints
<p>(BR1) The manager of a department must belong to that department.</p> <p>(BR2) An employee must not have a salary greater than that of the manager of the department to which he or she belongs.</p> <p>(BR3) A department of the Rome branch must be managed by an employee with more than 10 years' employment with the company.</p> <p>(BR4) An employee who does not belong to a particular department must not participate in any project.</p> <p>....</p>
Derivations
<p>(BR5) The budget for a project is obtained by multiplying the sum of the salaries of the employees who are working on it by 3.</p> <p>....</p>

An E-R schema with a few imprecisions

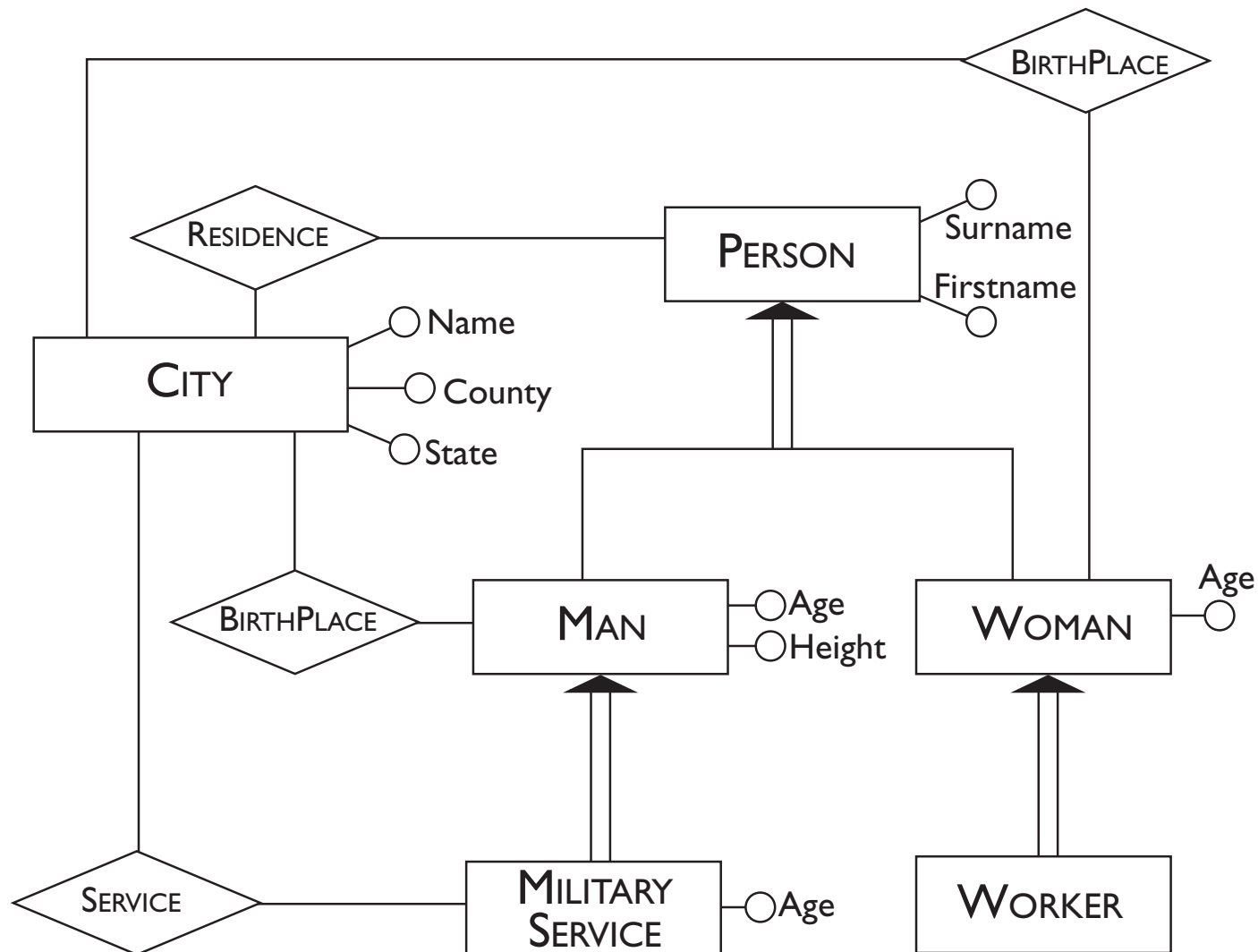

Schema E-R for Exercise 5.6

